

Programmable Deluxe Thermostat

F06-NS Series for Fan Coil Unit of AC Systems

Features

- ◆ Deluxe programmable thermostat for Fan Coil Unit of air conditioning systems. It's designed to maintain your desired room temperature by 7-days program.
- ◆ Many models for different FCU systems and also provide customized models.
- ◆ Setting and operation easily by perfect buttons and large LCD. Provides you a more comfortable and convenient living environment.
- ◆ Large LCD display with many messages for quick and easy checking and operation. Such as temperature measurement and set point, fan and valve working status, clock and program, etc.
- ◆ Attractive turn-cover design, most frequently used keys are located right beside the LCD for quick and easy operation. Program keys are located on the interior to eliminate accidental setting changes.
- ◆ Programmable control for your convenience with 7-day program of four time periods and four temperatures each day.
- ◆ All setup are kept on after the event of the power failure.
- ◆ Auto or manual fan speed switch selectable.
- ◆ °F or °C temperature display selectable.
- ◆ Constant hold feature allows continuous override.
- ◆ Temporary temperature override.
- ◆ Unique lockable function makes all keys locked to eliminate accidental operation.
- ◆ Key-card option keeps on the save energy temperature in non-occupancy for hotels and returns back automatically to the pre-set temperature once occupancy.
- ◆ Infrared remote control optional.
- ◆ Blue backlight optional
- ◆ RS485 communication interface optional

Buttons and LCD

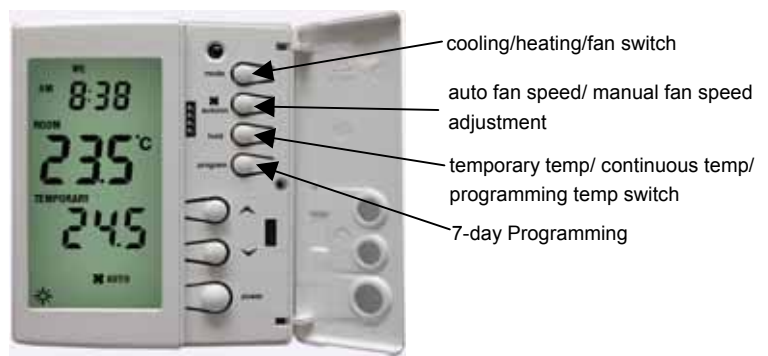

Specifications

Power supply	220VAC±10% / 110VAC±10%
Power consume	≤ 3W
Electrical rating	2 amp maximum load per terminal
Sensor	NTC 5K @25
Temperature degree	Celsius or Fahrenheit

Temperature control range (for heat/ cool)	5~35 (41~95)
Accuracy	±0.5 (±1) @25
Programmability	One week/7-day programmable and up to four time periods and temperatures pre-set for each day
LCD Display	91mm(L)X46mm(W)
Buttons	On the surface: power/ increase/ decrease Inside: for programming
Housing	PC/ABS plastic material with IP30 protection class
Net weight	370g
Dimensions	110mm(L)×90mm(W)×25mm(H) +28.5mm(back bulge)
Mounting standard	Mounting on the wall, 2"×4" or 65mm×65mm box

Shipping Information

Indiv. Ctn. Dim	135mm x 95mm x 55mm
Master Ctn. Qty	40
Master Ctn. Dim	44cm(L)X32cm(W)X32cm(H)
Master Ctn. Wt.	16KG

Models

MODEL	DESCRIPTION
F06-NS -20/21	3-speed fan control, 1*on/off output to control a 2-wire/3 wire water valve
F06-NS -20/21-K	3-speed fan control, 1*on/off output to control a 2-wire/3 wire water valve. Key-card function for occupancy & non-occupancy control.
F06-NSC-20/21	3-speed fan control, 1*on/off output to a 2-wire/3 wire water valve. RS485 communication interface
F06-NS-22	3-speed fan control, 2X on/off outputs to 2X 2-wire water valves for 4 pipes system
F06-NS-22-K	3-speed fan control, 2X on/off outputs to 2X 2-wire water valves for 4 pipes system. Key-card function for occupancy & non-occupancy control
F06-NSC-22	3-speed fan control, 2X on/off outputs to 2X 2-wire water valves for 4 pipes system. RS485 communication interface.
	OPTIONS
Blue Backlight of LCD -EL	Blue backlight display of LCD, two display modes selectable by end users
Remote Control -R	Infrared remote control

Wiring Diagrams

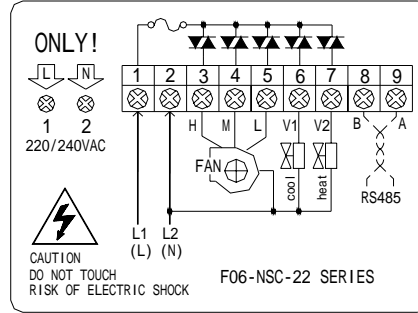
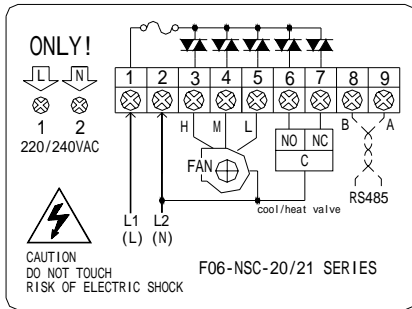
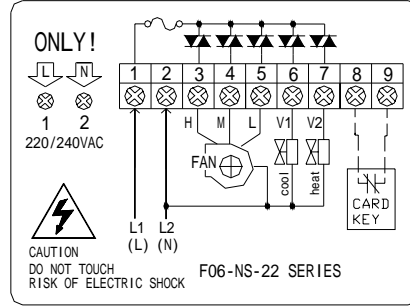
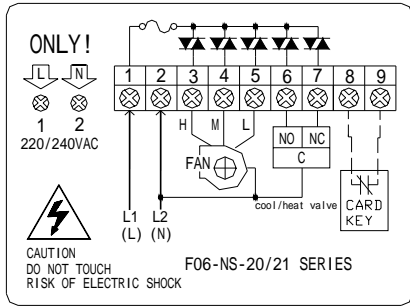

Mounting

