

ME3-H₂ Gas Sensors Manual

1 Feature

ME series H₂ sensors have low consumption , small size, high sensitivity, wide range of linearity , and better anti-jamming capacity, good reproducibility , stability and reliability ect advantage . It is electrochemical sensor widely suits for industry and environmental protection field ect .

2 Application

| Type | Detecting Object | Use | Remark |
|---------------------|------------------|---|--------|
| ME3- H ₂ | H ₂ | Detecting H ₂ in industry and environmental protection field | |

3 Feature

3.1 Parameter

3.1.1 Basic feature

| | | |
|-----------------------------------|-----------------------|----------------|
| Measurement Range | 0-1000ppm | Remark |
| Sensitivity(μA/ppm) | 0.05 ± 0.02 | |
| Reproducibility | Output signal ± 2% | |
| Response time(t ₉₀) s | ≤ 30 | |
| Signal attenuation | ≤ 2% | /month |
| Zero drift (ppm) | -10 ~ 10 | Clean air |
| Temperature range (°C) | -20 ~ +50 | |
| Temperature drift (ppm) | ≤ 10 | 20 ~ 50°C |
| Humidity range | ≤ 95%RH | |
| Pressure range (kPa) | 90 ~ 110 | |
| Storage temperature (°C) | 0 ~ 20 | Recommendation |
| Storage period (month) | 6 | |
| Anticipated using life (month) | > 24 | |
| Max detecting concentration (ppm) | 2000 | |

3.1.2 Products external dimension

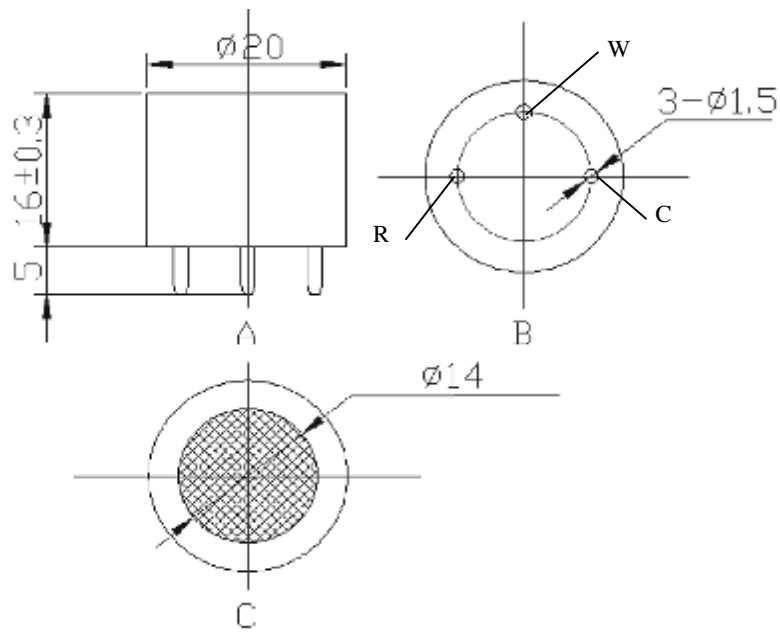

A—left view B—palmform C—upward view

Chart 1. products external demension

3.2 Gas sensitivity

3.2.1 ME3- H₂ type electrochemical sensor concentration response characteristic curve

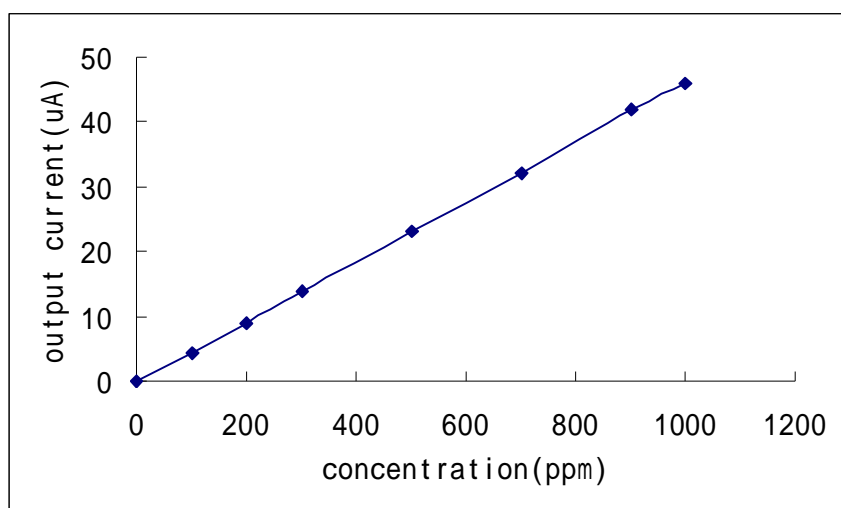

Chart 2 .sensitivity curve

3.2.2 ME3-H₂ type electrochemical sensor response , resume time and output current relation curve

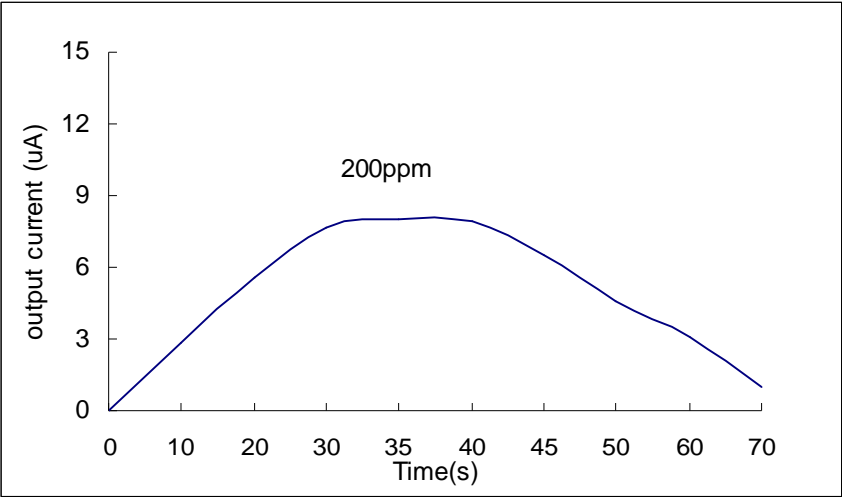

Chart 3 response and resume curve

3.2.3 Temperature characteristic

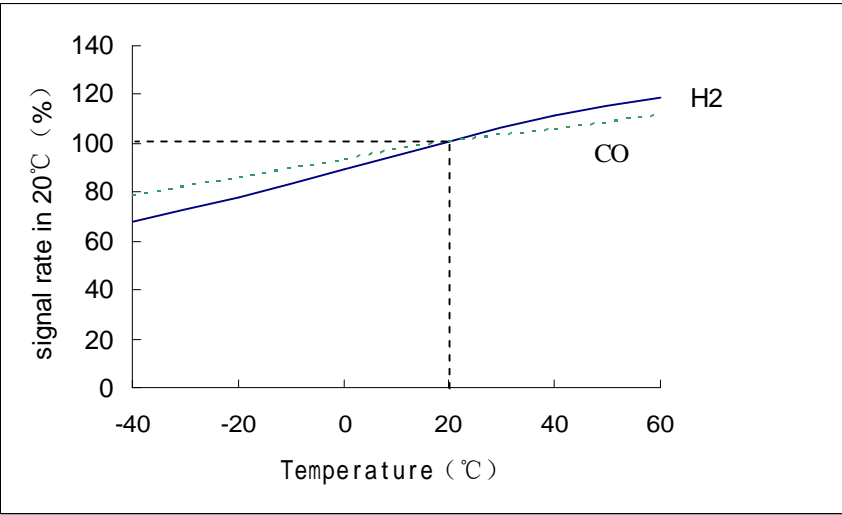

Chart 4. Temperature curve