

ME3-H₂S Gas Sensors Manual

1 Feature

ME series H₂S sensors have low consumption, small size, high sensitivity, wide range of linearity, and better anti-jamming capacity, good reproducibility, stability and reliability ect advantage. It is electrochemical sensor widely suits for mine, industry and environmental protection field ect.

2 Application

Type	Detecting Object	Use	Remark
ME3-H ₂ S	H ₂ S	Detecting H ₂ S in industry, mine and environmental protection field	

3 Feature

3.1 Parameter

3.1.1 Basic feature

Type	ME3-H ₂ S	Remark
Measurement Range	0-200	
Sensitivity(μA/ppm)	1.0±0.2	
Reproducibility	Output signal±2%	
Response time(t ₉₀) s	≤30	
Signal attenuation	≤2%	/month
Zero drift (ppm)	-0.2~0.3	Clean air
Temperature range (°C)	-20~+50	
Temperature drift (ppm)	≤0.5	20~50°C
Humidity range	≤95%RH	
Pressure range (kPa)	90~110	
Storage temperature (°C)	0~20	recommendation
Storage period (month)	6	
anticipated using life (month)	>24	
Max detecting concentration (ppm)	300	

3.1.2 Products external dimension

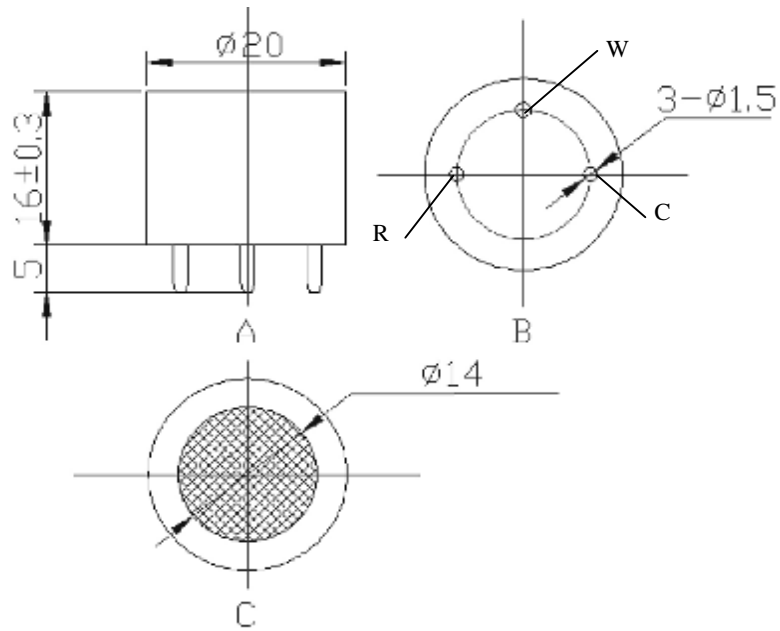

A—left view B—planform C—upward view
chart 1 products external dimension

3.2 Gas sensitivity

3.2.1 H₂S Electrochemical sensor concentration response characteristic curve

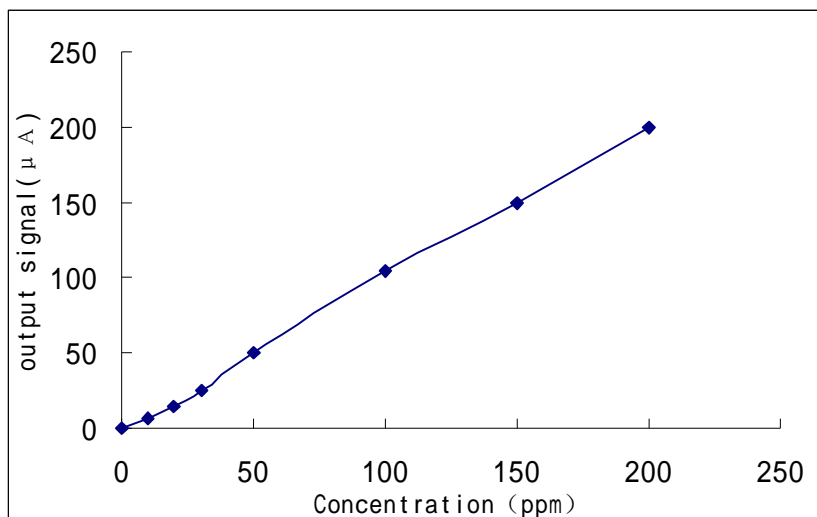

Chart 2 .sensitivity curve

3.2.2 Response and resume time characteristic curve

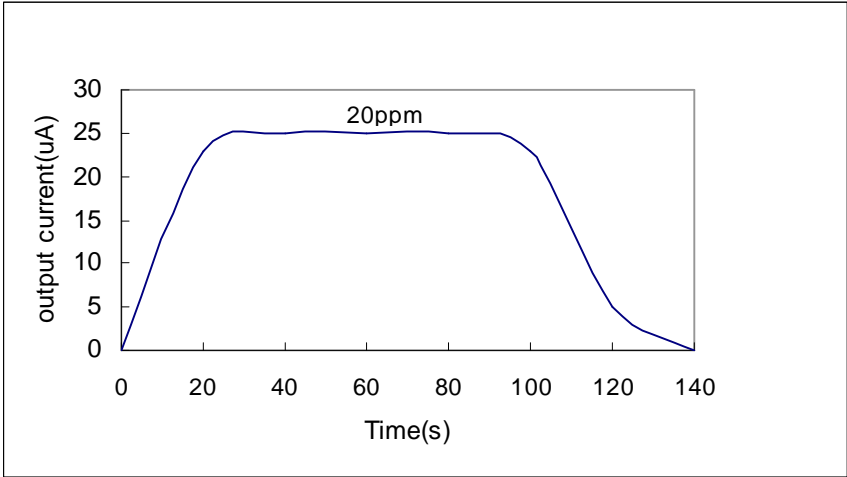

Chart 3.Response and resume curve

3.2.3 Temperature characteristic

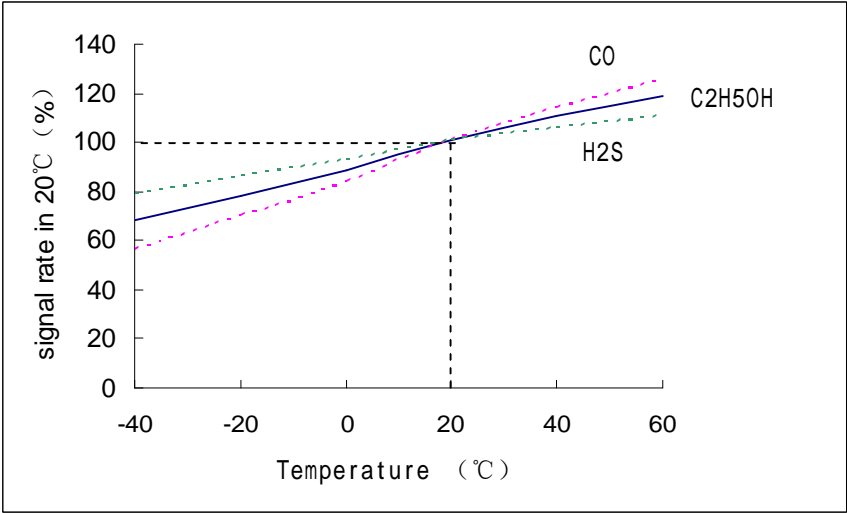

Chart 4.temperature curve